

INSTRUCTION MANUAL

INDUCTIVE POSITIONING SYSTEM -F90

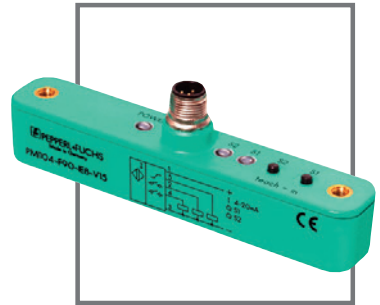

1	System overview	5
2	Sensor versions	5
2.1	Version PMI...-F90-IU-V1	6
2.2	Version PMI...-F90-IE8-V15	6
3	Attenuating element	7
4	Installation and operation	7
4.1	Notes on installation	7
4.2	Notes on operation	8
4.3	Definition of measuring range / of measured position	8
5	Technical data	9
5.1	General, electrical and mechanical data	9
5.2	Electrical connection:	9
5.3	Dimensions	10
6	Accessories	11
6.1	Attenuating elements	11
6.2	Mounting brackets	11

Used symbols



Warning

This symbol warns the user of potential danger. Nonobservance may lead to personal injury or death and/or damage to property.



Attention

This symbol warns the user of potential device failure. Nonobservance may lead to the complete failure of the device or other devices connected.



Note

This symbol calls attention to important notes.

Security advice**Warning**

*This product must not be used in applications, where safety of persons depend on the correct device function.
This product is not a safety device according to EC machinery directive.*

Notes

These operating instructions refer to proper and intended use of this product. They must be read and observed by all persons making use of this product. This product is only able to fulfill the tasks for which it is designed if it is used in accordance with specifications of Pepperl+Fuchs.

The warrantee offered by Pepperl+Fuchs for this product is null and void if the product is not used in accordance with the specifications of Pepperl+Fuchs.

Changes to the devices or components and the use of defective or incomplete devices or components are not permitted. Repairs to devices or components may only be performed by Pepperl+Fuchs or authorized work shops. These work shops are responsible for acquiring the latest technical information about Pepperl+Fuchs devices and components. Repair tasks made on the product that are not performed by Pepperl+Fuchs are not subject to influence on the part of Pepperl+Fuchs. Our liability is thus limited to repair tasks that are performed by Pepperl+Fuchs.

The preceding information does not change information regarding warrantee and liability in the terms and conditions of sale and delivery of Pepperl+Fuchs.

This device contains sub-assemblies that are electrostatically sensitive. Only qualified specialists may open the device to perform maintenance and repair tasks. Touching the components without protection involves the risk of dangerous electrostatic discharge, and must be avoided. Destruction of basic components caused by an electrostatic discharge voids the warrantee!

Subject to technical modifications.

Pepperl+Fuchs GmbH in D-68301 Mannheim maintains a quality assurance system certified according to ISO 9001.



1 System overview

The new inductive position encoding system F90 is optimised for a high-precision, continuous position detection.

Based on the high-precision evaluation of multiple coil systems, the position encoding system F90 is a combination of tried and tested inductive sensor technology and innovative microcontroller technology.

The compact and robust design F90 allows for a contactless and thus wear-free position detection in measuring lengths of 80 mm, 104 mm and 120 mm. Thanks to the integrated temperature compensation, it is also optimally suited for rough environments and critical positioning tasks.

Due to the inductive principle of operation, you do not need any ferrites or magnets as a counterpart. As in the case of an inductive proximity switch, the actuator can be made of any metal.

The advantages of the inductive position encoding system F90 are:

- High resolution and accuracy
- Minimum temperature drift
- Contactless
- Teach-in (version PMI...-F90-IE8-V15)
- Low interference sensitivity due to inductive principle of operation

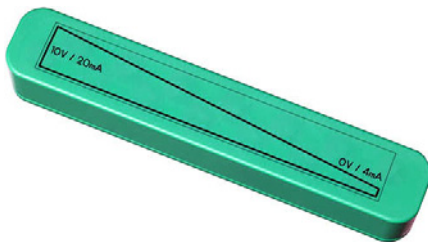

2 Sensor versions

The inductive position encoding system F90 is available in two basic versions.

In the version PMI...-F90-IU-V1, the position encoding system provides a current and voltage signal at the outputs, which is proportional to the position of the attenuating element.



Attention

Only one current or voltage output can be used at a time. Depending on the load connected, a simultaneous use of both outputs causes the output characteristics to be falsified.

In addition to a current signal, the version PMI...-F90-IE8-V15 offers the possibility to teach in 2 switching points independently of each other by a simple key stroke directly on the sensor and to represent them by 2 switch outputs. The output states of the two switch outputs are indicated by 2 additional LEDs.

2.1 Version PMI...-F90-IU-V1

Output signals:

- 4 mA ... 20 mA
- 0 V ... 10 V

The sensors of the version PMI...-F90-IU-V1 are available in 3 different lengths with respective measurement ranges.



Length	Measurement range	Order code
102 mm	80 mm	PMI80-F90-IU-V1
126 mm	104 mm	PMI104-F90-IU-V1
142 mm	120 mm	PMI120-F90-IU-V1

2.2 Version PMI...-F90-IE8-V15

Output signals:

- 4 mA ... 20 mA
- 2 programmable switching stages

The sensors of the version PMI...-F90-IE8-V15 are available in 3 different lengths with respective measurement ranges.



Length	Measurement range	Order code
102 mm	80 mm	PMI80-F90-IE8-V15
126 mm	104 mm	PMI104-F90-IE8-V15
142 mm	120 mm	PMI120-F90-IE8-V15

Programming the PMI...-F90-IE8-V15

The sensor PMI...-F90-IE8-V15 is equipped with 2 small keys at the rear, which are arranged in a slightly recessed position, for programming the switching points. The keys are labelled "teach - in" and S1 for the switching point S1 and S2 for the switching point S2.

For teach-in of a switching point, proceed as follows:

- The attenuating element for position detection must be placed at the desired position, i.e. the switching point for teach-in.
- Now actuate the respective 2 pushbuttons for at least 2 seconds. The related switching state LED starts to flash and thus indicates that the sensor is now in "Teach-in mode".
- Confirm the desired switch point by pressing the key again. The switching state LED now lights continuously as long as the attenuating element is not moved.

Teach-in of the switch point is now complete. Within an adjustable range of the actuator of ± 1 mm around the learned switching point, the related switch output switches into the active state.



Attention

If the switching point is not confirmed within 80 seconds, the sensor leaves the "Teach-in mode" and continues the operation with the previous values.

3 Attenuating element

The inductive position encoding system F90 is optimally adjusted to the geometry of the attenuating elements we offer (see chapter 6.1 "Attenuating elements" at page11).

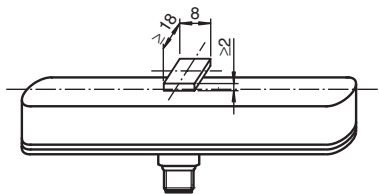

Attention

When using your own attenuating elements, you must ensure that the active surface of the attenuating element has a width of exactly 8 mm and overlaps the entire sensor width.

A different width has a direct impact on the achievable resolution and accuracy of the system.

4 Installation and operation

4.1 Notes on installation

- A flush installation is possible.
- To extend the measurement range, the inductive position encoding system F90 may be mounted in rows (both side by side as well as one after the other) without minimum distance.

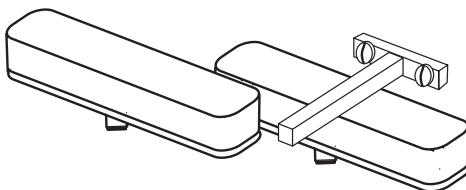

- When the fixing screws are selected, the maximum screw-in depth in the threaded inserts of 8 mm must be observed.



Attention

If the fixing screws are screwed in too deep, the sensor may be damaged.

- The distance between the measuring field (bordered area at the front of the sensor) and the fixing base or fixing element of the attenuating element must at least be 3 mm.

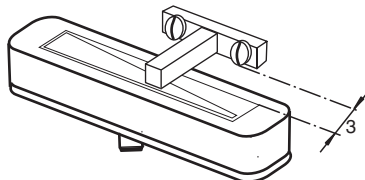
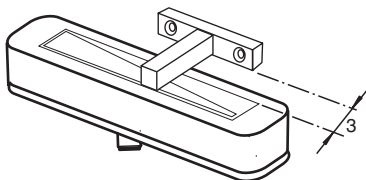

4.2 Notes on operation

When the attenuating element leaves the measurement range (figures below):

- the last valid value is maintained at the voltage output (only PMI...-F90-IU-V1) until the attenuating element re-enters the valid range.
- the last valid value is maintained at the current output (all types) for 0.5 seconds. Afterwards, the output changes to a fault current of 3.6 mA until the attenuating element re-enters the valid range.
- the switching stages keep the current state for 0.5 seconds. Afterwards, an active switch output changes into the quiescent state ("Open" position).

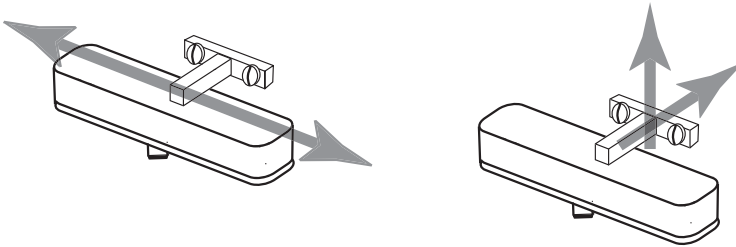

4.3 Definition of measuring range / of measured position

The measured attenuating elements (actuators) position refers to half its width (middle of the actuator). The measuring range starts and ends when the attenuating element overlaps the labeled measuring area on the sensor at transversal motion (see left figure above).

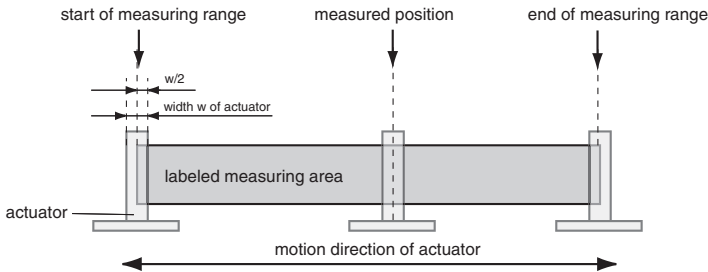

5 Technical data

5.1 General, electrical and mechanical data

Type	PMI...-F90-IU-V1	PMI...-F90-IE8-V15
General data		
Output functions	Analogue current and voltage output	Analogue current output and 2 switching outputs
Object distance	max. 3 mm	
Installation	Flush	
Reduction factor r_{AI}	0.45	
Reduction factor r_{Cu}	0.4	
Reduction factor r_{V2A}	0.75	
Measurement range	0 ... 80 mm, 0 ... 104 mm or 0 ... 120 mm, depending on the type	
Characteristics		
Operating voltage U_B	18 ... 30 V	
Polarity protection	Reverse polarity protected	
Short circuit protection	pulsing	
Output current	4 ... 20 mA	
Output voltage	0 ... 10 V	-
Voltage drop U_d	-	≤ 3 V
Linearity fault	± 0.4 mm	
Temperature drift	± 0.5 mm (-25 °C ... 70 °C)	
Repeat accuracy	± 0.1 mm	
Repeat frequency	≤ 200 Hz	
Resolution	125 μm	
Operating current I_L	-	0 ... 100 mA
No load current I_0	≤ 35 mA	
Load resistance	Current output: < 400 Ω	
	Voltage output: > 1000 Ω	-
Operating voltage display	Green LED	
Switching window	-	learned switching point ± 1 mm
Switching state display	-	2 LEDs yellow
Standards compliance		
EMC according to	EN 60947-5-2:2004	
Standards	EN 60947-5-2:2004	
Ambient conditions		
Ambient temperature	-25 ... 70 °C (248 ... 343 K)	
Storage temperature	-40 ... 85 °C (233 ... 358 K)	
Mechanical data		
Connection type	M12 connector, 4-pin	M12 connector, 5-pin
Housing material	ABS	
Protection degree	IP67	
Protection class	II	

Note: The accuracy values only apply for a distance of the object to be detected of 1 ... 3 mm.

5.2 Electrical connection:

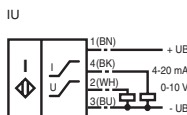

PMI...-F90-IU-V1

It can be connected via connector M12 x 1, 4-pin

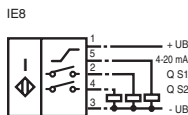

PMI...-F90-IE8-V15

It can be connected via connector M12 x 1, 5-pin

5.3 Dimensions



Note

Only the dimension drawings of the respective comfort version are shown. The dimensions of the basic version are identical, but do not have the buttons and LEDs labelled S1 and S2.

Measurement range 80 mm

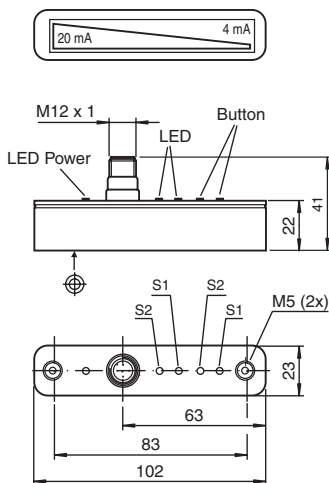

Measurement range 104 mm

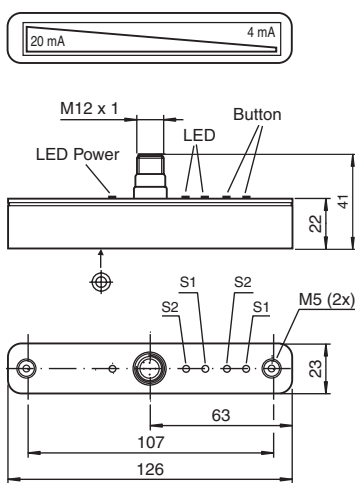

Measurement range 120 mm

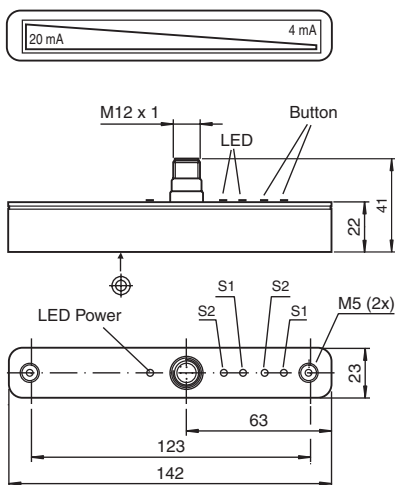

Date of edition: 2006/09/22
 Part No. 189292
 Document No. DOCT-0902A

6 Accessories

6.1 Attenuating elements

BT-F90-G

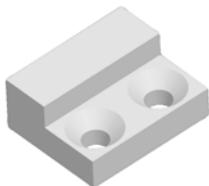

Material: steel ST37

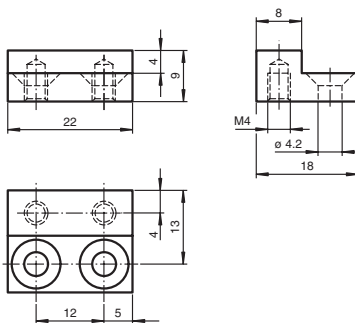

BT-F90-W



Material: steel ST37

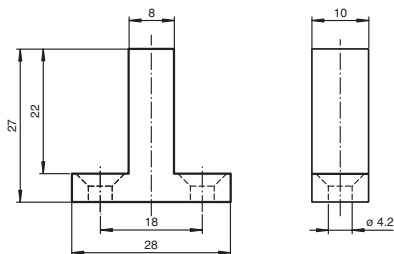

6.2 Mounting brackets

MH-F90

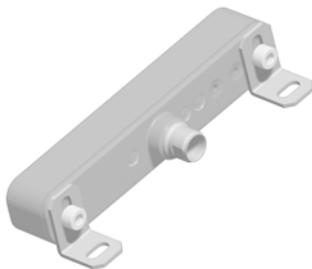

Material: sheet metal, zinc coated
Scope of delivery: 2 units

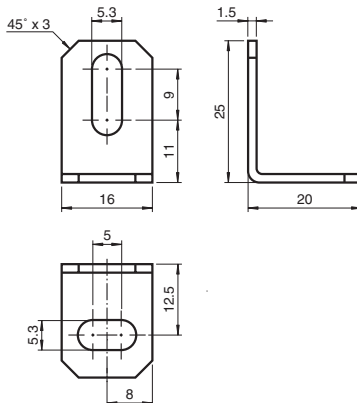

Part No. 188382 Document No. DOCT-0902A

Date of edition: 2006/06/22



FACTORY AUTOMATION

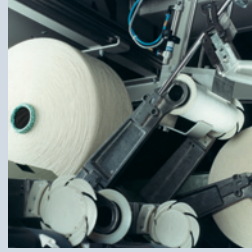

SIGNALS FOR THE WORLD OF AUTOMATION

For half a century Pepperl+Fuchs has continually provided new impetus to the world of automation. We develop, manufacture and market electronic sensors and interface modules through our worldwide network. Our global presence and highly flexible production and service organisations enable us to offer you complete individual solutions – right where you need us! We know what we're talking about – because today Pepperl+Fuchs is the company with the largest selection of industrial sensors technology in the World – serving a very broad spectrum of applications. **Our signals move the World.**



www.pepperl-fuchs.com

Worldwide Headquarters

Pepperl+Fuchs GmbH · Königsberger Allee 87
68307 Mannheim · Germany
Tel. +49 621 776-0 · Fax +49 621 776-1000
e-mail: fa-info@de.pepperl-fuchs.com

USA Headquarters

Pepperl+Fuchs Inc. · 1600 Enterprise Parkway
Twinsburg, Ohio 44087 · USA
Tel. +1 330 4253555 · Fax +1 330 4254607
e-mail: sales@us.pepperl-fuchs.com

Asia Pacific Headquarters

Pepperl+Fuchs Pte Ltd. · P+F Building
18 Ayer Rajah Crescent · Singapore 139942
Tel. +65 67799091 · Fax +65 68731637
e-mail: sales@sg.pepperl-fuchs.com



 **PEPPERL+FUCHS**

SIGNALS FOR THE WORLD OF AUTOMATION