

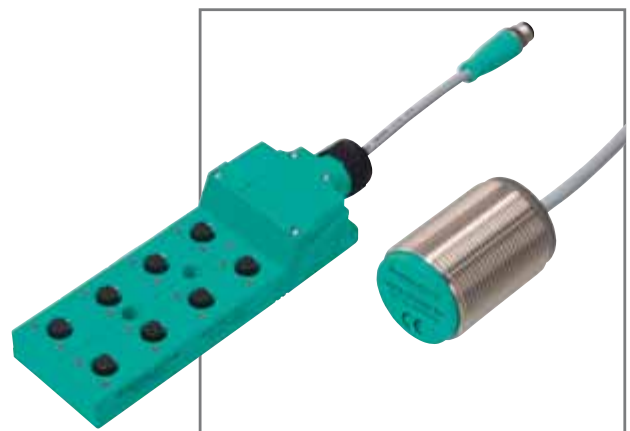

WIRELESS COMMUNICATION AND ENERGY TRANSFER

WIS

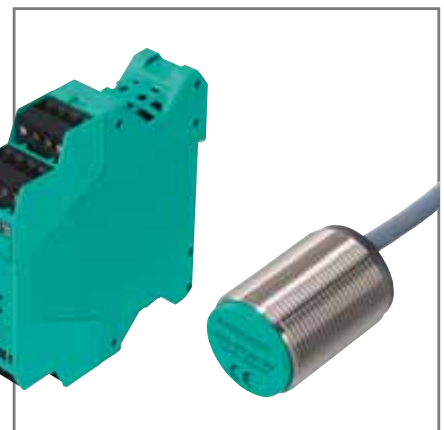

It is always a challenge within the automation industry to connect sensor components on moveable machine parts. Solutions using drag chains or slip rings are always vulnerable to wear and tear regardless of their mechanical design. Thus, their durability is limited and higher maintenance costs are incurred. The new Wireless Inductive System –WIS– designed by Pepperl+Fuchs is a clever and efficient solution for these applications.

More freedom for machine designers

The system consists of 4 components and enables wireless power transfer and wireless communication for sensors on moveable parts of the machine. Up to 1.5 watts is transferable at a maximum operating distance of 5 mm. Inductive, capacitive, optical or ultrasonic sensors can be connected. WIS offers a maintenance free solution to operate up to 8 sensors wirelessly.

Typical applications are:

- Tool change on rotary tables or in a press shop
- Object detection on a work piece holder
- Component manufacturing
- Robot grippers
- Rotary tools

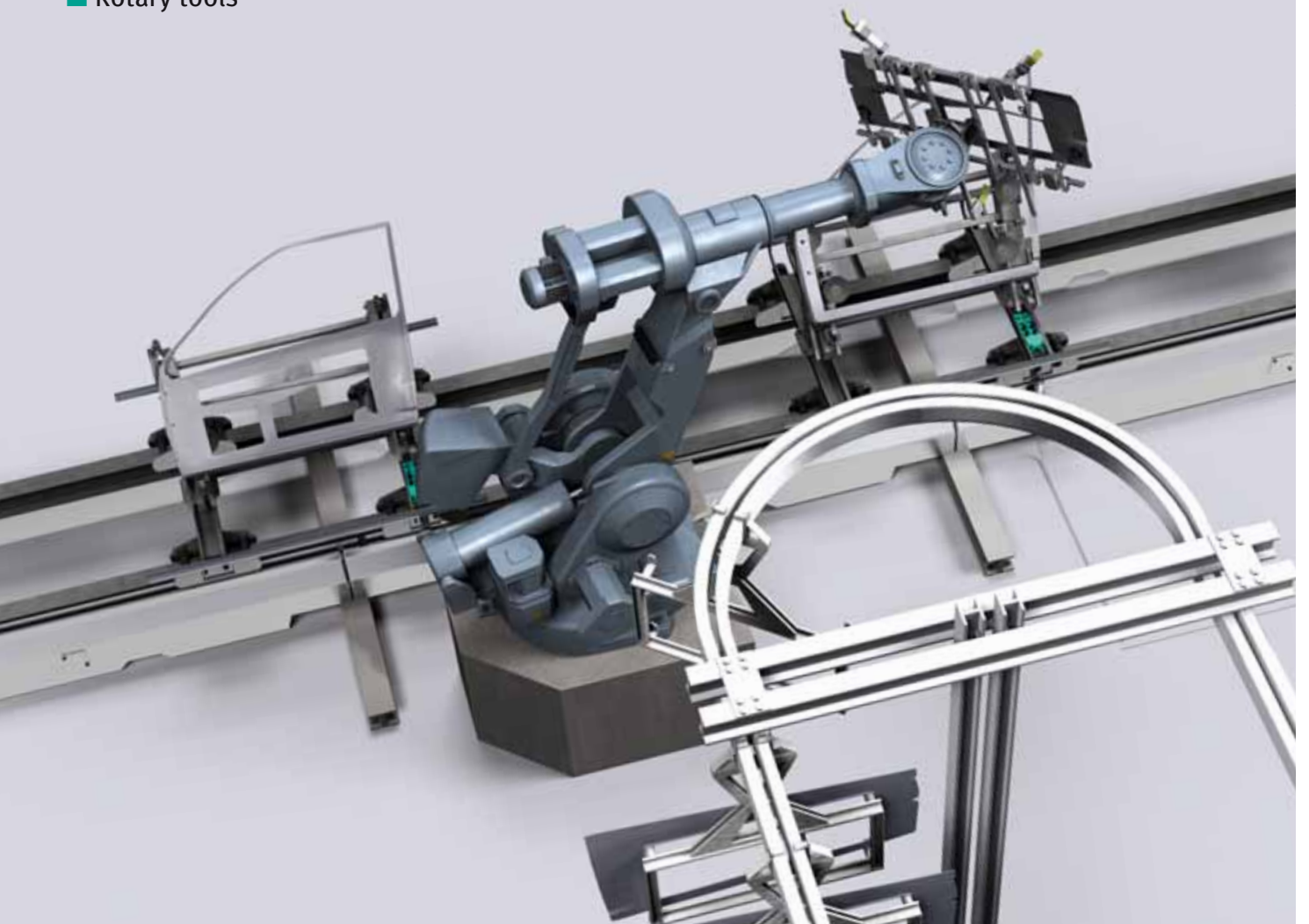



PRIMARY SIDE

Modular concept



Increases plant availability

SECONDARY SIDE

**Robust and
maintenance free**

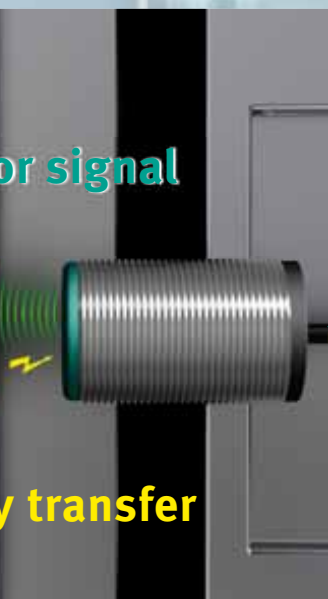

Up to 8 sensors



**Communication
Energy Transfer**



More flexibility

PRIMARY SIDE

NDP-KE2-8E2

Number of sensor channels	8 switch outputs pnp, NO
Signal transfer direction	From secondary side to primary side
Operating voltage	24 V DC
Current consumption	Max. 1000 mA
Display of sensor states	Yes
Display of transfer status	Yes
Mounting	DIN rail



NDP5-30GM-5M

Transfer distance	0 mm ... 5 mm
Design	M30
Installation	Not embeddable
Connection	Cable, 5 m
Protection class	IP67



SECONDARY SIDE

NDS5-30GM-1M-V1

Transfer distance	0 mm ... 5 mm
Design	M30
Installation	Not embeddable
Connection	Cable, 5 m with plug M12 x 1, 4-pin
Protection class	IP67

NDS-F146-8E2-V1

Number of sensor channels	8
Signal transfer direction	From primary side to secondary side
Current operating voltage	12 V ± 10 %, protected against overload and short-circuit
Transferred output	Max. 1,5 W
Suitable sensor types	DC, 3-wire, PNP
Sensor connections	M12 x 1, 4-pin
Protection class	IP65



FACTORY AUTOMATION – SENSING YOUR NEEDS



Pepperl+Fuchs sets the standard in quality and innovative technology for the world of automation. Our expertise, dedication, and heritage of innovation have driven us to develop the largest and most versatile line of industrial sensor technologies and interface components in the world. With our global presence, reliable service, and flexible production facilities, Pepperl+Fuchs delivers complete solutions for your automation requirements – wherever you need us.

Contact

Pepperl+Fuchs GmbH
Lilienthalstraße 200
68307 Mannheim · Germany
Tel. +49 621 776-4411 · Fax +49 621 776-27-4411
E-mail: fa-info@de.pepperl-fuchs.com

Worldwide Headquarters

Pepperl+Fuchs GmbH · Mannheim · Germany
E-mail: fa-info@de.pepperl-fuchs.com

USA Headquarters

Pepperl+Fuchs Inc. · Twinsburg · USA
E-mail: fa-info@us.pepperl-fuchs.com

Asia Pacific Headquarters

Pepperl+Fuchs Pte Ltd · Singapore
Company Registration No. 1999003130E
E-mail: fa-info@sg.pepperl-fuchs.com

www.pepperl-fuchs.com

 **PEPPERL+FUCHS**
SENSING YOUR NEEDS